

CERTIFICATION



HACCP International



ISO9001

ICE MATE



SRM-125A ICE MAKER

ICEMATE is committed to bringing high-efficiency / energy-saving, and high quality ice-making product to people who have dreams and desire to create their own business with the best scientific technology and manufacturing technology.

DICE

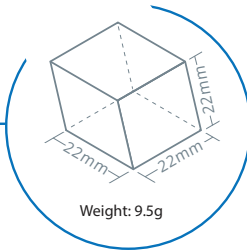

KEY FEATURES

SAFETY AND HYGIENE ASSURED ICE MACHINE



NSF Certified Material for Bin and Scoop

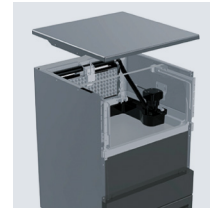

Detachable Parts for Easy Cleaning



Air Filter Prevent Dust from Entering



Stainless Steel

ENERGY & WATER SAVING, QUIET OPERATION



Energy & Water Saving, Quiet Operation

EASY MAINTENANCE



IoT



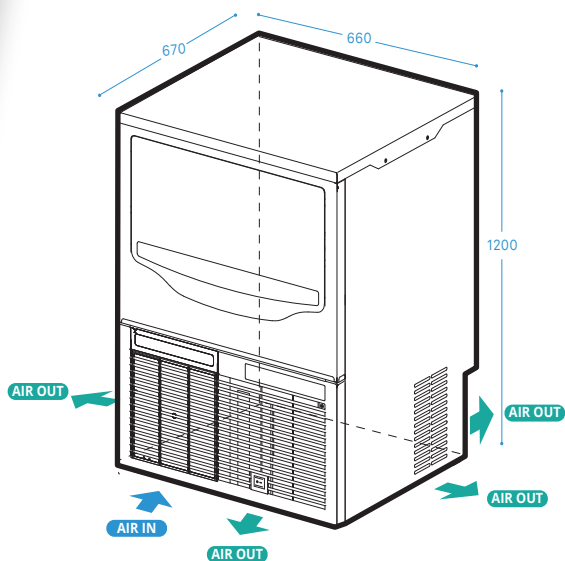

TOP SIDE

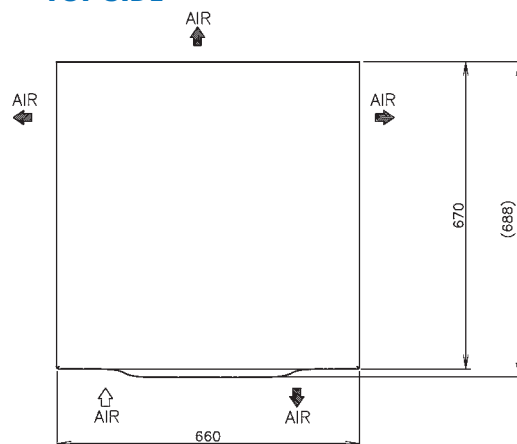

FRONT SIDE

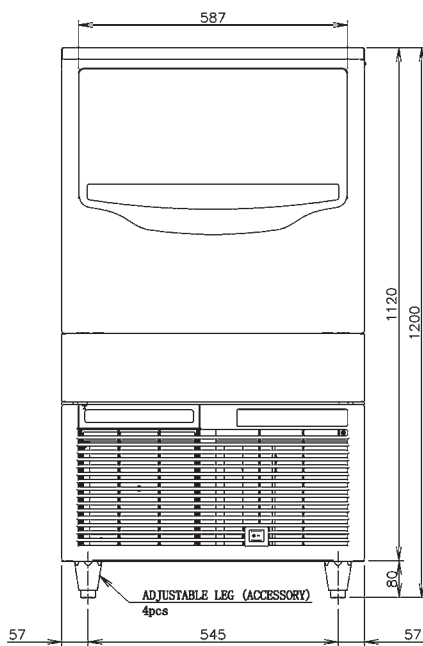

RIGHT SIDE

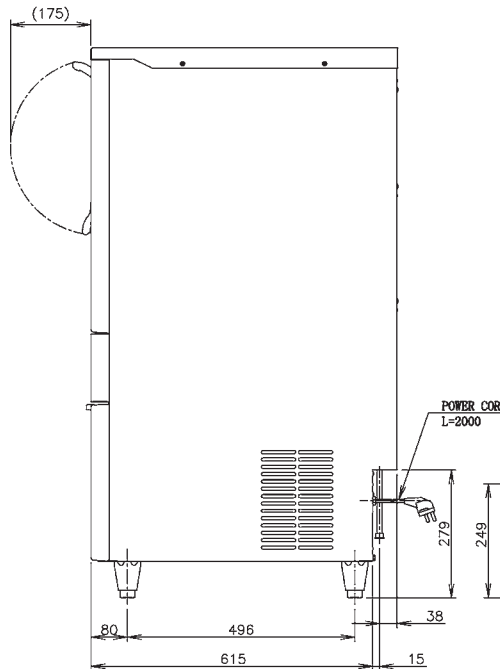

BACK SIDE

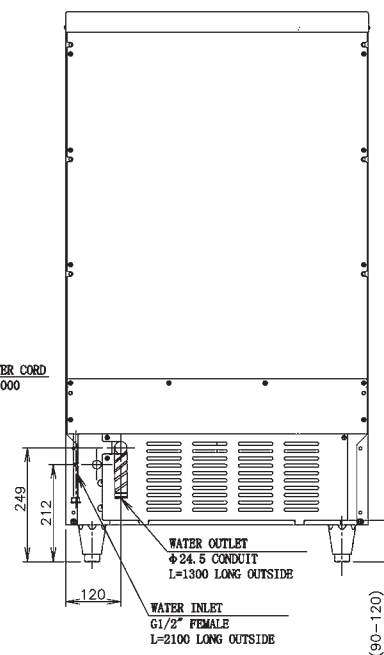

SPECIFICATIONS

Ice Dimensions (W x D x H)	22 x 22 x 22 mm
Outside Dimensions (W x D x H)	660 x 670 x 1200 mm
Package Dimensions (W x D x H)	Carton: 785 x 860 x 1250 mm
Weight (Net / Gross)	64.5 kg / 72 kg
Amperage / Starting Amperage	3.9A / 18.4A
Electrical Consumption	(AT32°C / WT21°C) 590 W
Refrigerant Charge	R404A / 350g
Ice Storage Capacity	Maximum 43.6kg
Ice Production per 24H	(AT10°C / WT10°C) Approx. 125 kg (AT21°C / WT15°C) Approx. 106 kg (AT32°C / WT21°C) Approx. 81 kg

Water Consumption per 24H	(AT32°C/WT21°C) 0.17m ³ (2.1L / kg Ice)
Ice Production Freeze Cycle Time	(AT21°C/WT15°C) 15 min
Ice Production per Cycle	(AT21°C/WT15°C) Approx. 1.17kg / 126 pcs

OPERATING CONDITIONS

Voltage Range	198 - 254 V
Ambient Temperature	5 - 38°C
Water Supply	5 - 32°C
Water Supply Pressure	0.07 - 0.55 Mpa (0.7 - 5.5 bar)
Supply Voltage	1/220 - 240V / 50Hz



HOSHIZAKI

HOSHIZAKI MALAYSIA SDN. BHD.

No. 12, Jalan Penyajak U1/45B. Hicom-Glenmarie Industrial Park, 40150 Shah Alam, Selangor
TEL (+60) 3 5569 8023 | <https://hoshizaki.com.my/>